



COMPACT-GRID[®] CONVEYOR BELTS

IMPROVE EFFICIENCIES AND YOUR BOTTOM LINE

WWW.WIREBELT.COM



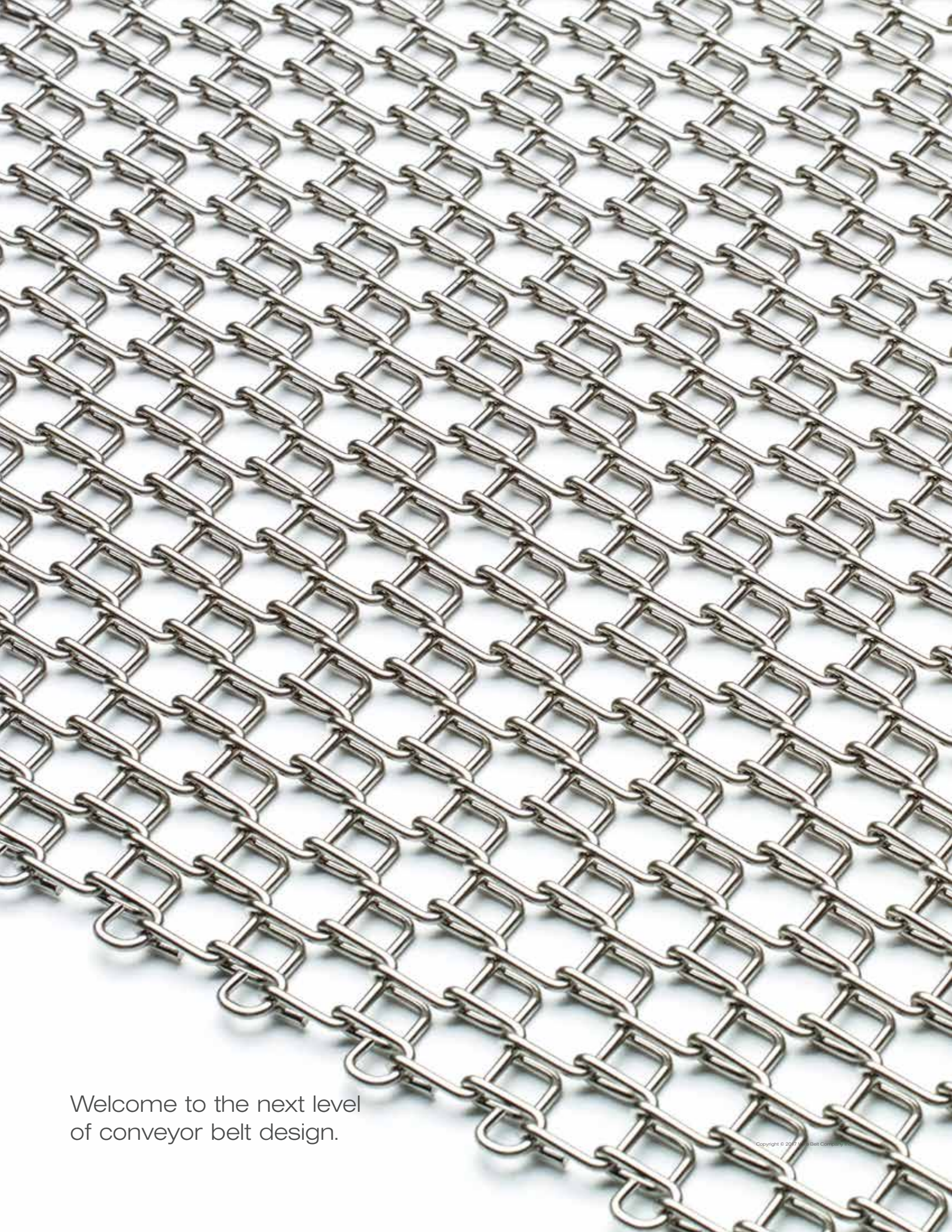

Welcome to the next level
of conveyor belt design.

COMPACT-GRID® CONVEYOR BELTS

Introducing Compact-Grid® conveyor belt, Wire Belt Company's next level of conveyor belt design. Compact-Grid conveyor belt's robust grid pattern maximizes belt life making Compact-Grid the perfect conveyor belt for your light to medium-duty range of applications.

Compact-Grid has many innovative features that make it the perfect conveyor belt for numerous applications. Compact-Grid can take on demanding processes and is easy to install and maintain on your conveyor. You'll love Compact-Grid for its clean-in-place design for easy sanitation.

ADVANTAGES

- USDA accepted
- Strong and long lasting
- Belt joining is fast and simple
- Positive drive design for excellent belt tracking
- Easy to sanitize, clean-in-place, saves time and money
- Superior support for smaller products

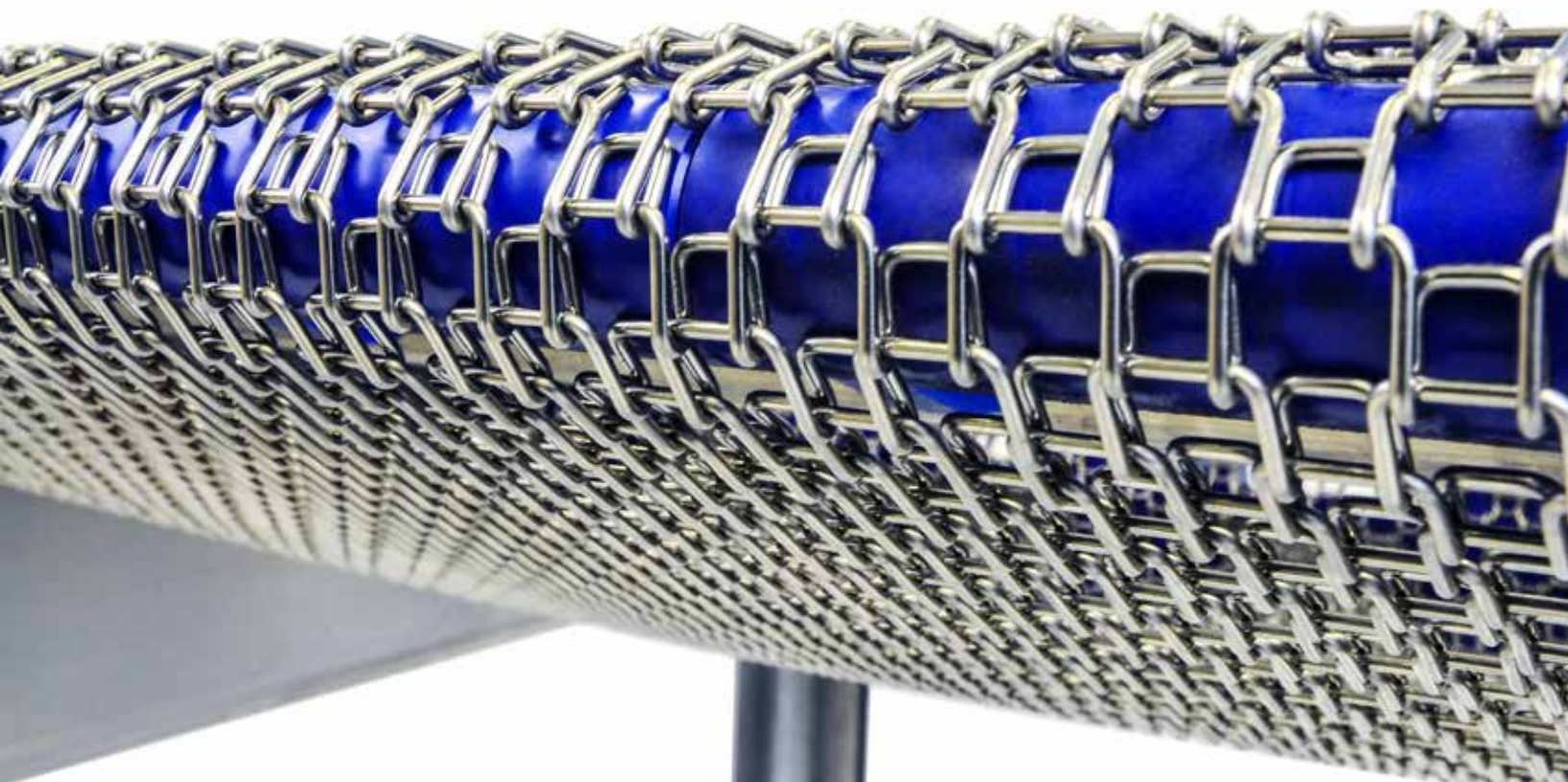

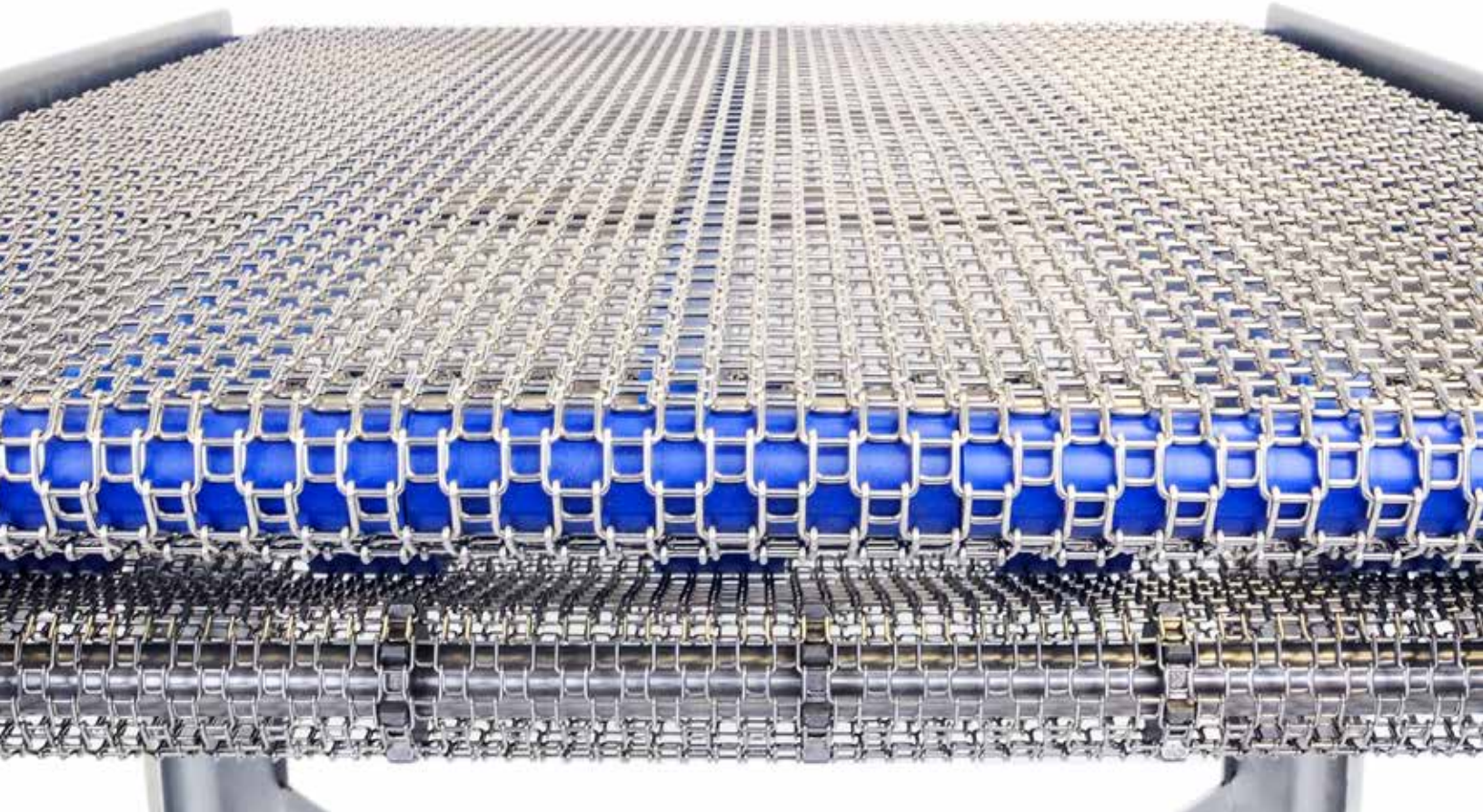

COMPACT-GRID® CONVEYOR BELTS

TYPICAL APPLICATIONS

Compact-Grid® conveyor belt is designed for maximum product support and has many varied applications.

Some of the typical applications are listed. If you have an application that is not on the list, contact our Technical Sales Engineers to see if Compact-Grid is right for your needs.

- Baking
- Breeding
- Coating
- Cooling
- Cooking
- Drying
- Elevating
- Enrobing
- Freezing
- Frying
- Heating
- Washing

10MM

15MM

* PHOTO NOT TO SCALE

COMPACT-GRID[®] 10mm (CG10)

STANDARD BELT DATA

Pitch	.394"	10mm
Space Width (average)	.394"	10mm
Wire Diameter	.063"	1.6mm
Belt Thickness	.20"	5.2mm
Weight	1.0lbs/ft ²	4.9 kg/m ²
Percent Open Area	71%	71%
Opening Size (largest opening)	ø.42" circle	ø10.6mm circle
Max Width	144.96"	3682mm
Min Width	11.1"	282mm
Max Working Tension	5lb/joint (150lb/ft)	2.27 kg/joint • 227 kg/mtr width
Min Transfer Diameter	.63"	16mm
Min Drive Sprocket Diameter	2"	51mm (8 teeth)
Available Materials	1.4310 (302) Stainless Steel 1.4436 (316) Stainless Steel	

*Smaller sizes available upon request.

5.2mm [0.20"]
Belt Thickness

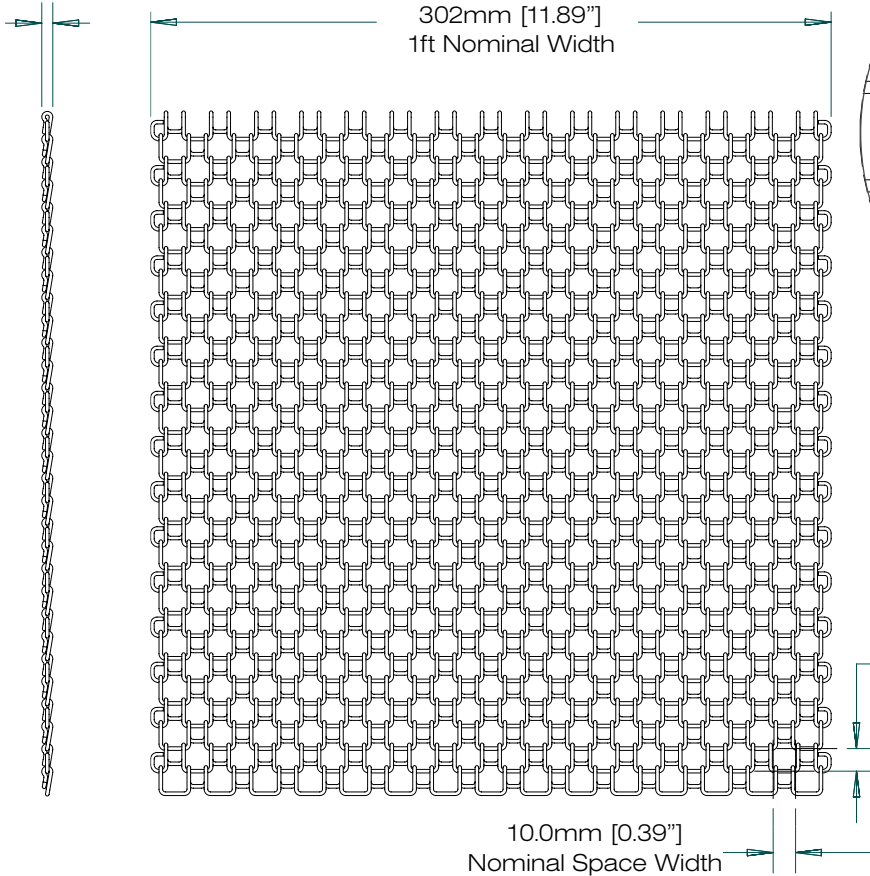

ø10.6mm [ø0.42"]
LARGEST CIRCULAR OPENING

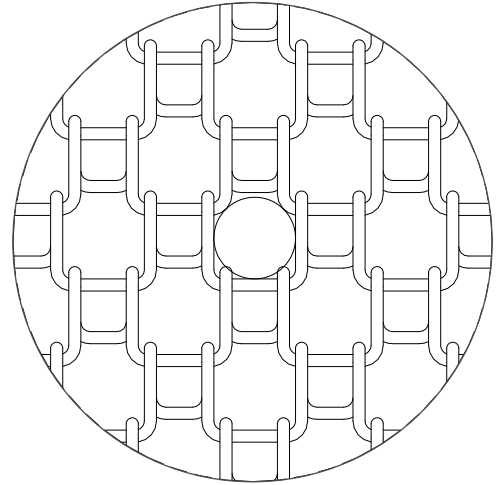

6.0mm [0.24"]
END SIZE

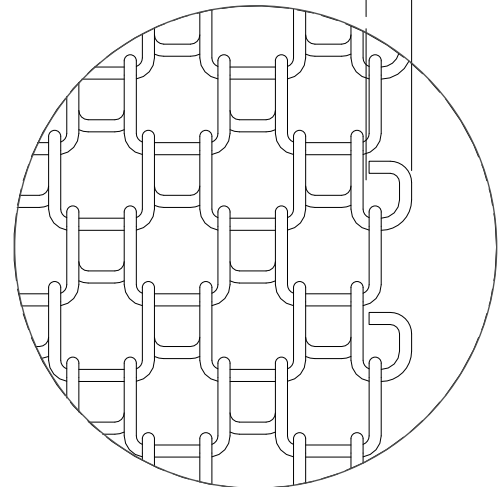

SCALE 1 : 1

10.0mm
[0.39"]

COMPACT-GRID[®] 10mm (CG10)

BELT WIDTH AVAILABILITY

Belt No.	No. of Spaces	Overall Belt Width		Standard # of Slim Profile Sprockets	Standard # of Stacking Drive Sets
		mm	inches		
CG00000	27	282	11.102	3	2
CG00001	29	302	11.890	4	3
CG00002	31	322	12.677	4	3
CG00003	33	342	13.465	4	3
CG00004	35	362	14.252	4	3
CG00005	37	382	15.039	4	3
CG00006	39	402	15.827	4	3
CG00007	41	422	16.614	5	3
CG00008	43	442	17.402	5	3
CG00009	45	462	18.189	5	3
CG00010	47	482	18.976	5	3
CG00011	49	502	19.764	5	4
CG00012	51	522	20.551	5	4
CG00013	53	542	21.339	6	4
CG00014	55	562	22.126	6	4
CG00015	57	582	22.913	6	4
CG00016	59	602	23.701	6	4
CG00017	61	622	24.488	6	4
CG00018	63	642	25.276	6	4
CG00019	65	662	26.063	7	4
CG00020	67	682	26.850	7	5
CG00021	69	702	27.638	7	5
CG00022	71	722	28.425	7	5
CG00023	73	742	29.213	7	5
CG00024	75	762	30.000	7	5
CG00025	77	782	30.787	8	5
CG00026	79	802	31.575	8	5
CG00027	81	822	32.362	8	5
CG00028	83	842	33.150	8	5
CG00029	85	862	33.937	8	5
CG00030	87	882	34.724	8	6
CG00031	89	902	35.512	9	6
CG00032	91	922	36.299	9	6
CG00033	93	942	37.087	9	6
CG00034	95	962	37.874	9	6
CG00035	97	982	38.661	9	6
CG00036	99	1002	39.449	9	6
CG00037	101	1022	40.236	10	6
CG00038	103	1042	41.024	10	6
CG00039	105	1062	41.811	10	7
CG00040	107	1082	42.598	10	7
CG00041	109	1102	43.386	10	7
CG00042	111	1122	44.173	10	7
CG00043	113	1142	44.961	11	7

Belt No.	No. of Spaces	Overall Belt Width		Standard # of Slim Profile Sprockets	Standard # of Stacking Drive Sets
		mm	inches		
CG00044	115	1162	45.748	11	7
CG00045	117	1182	46.535	11	7
CG00046	119	1202	47.323	11	7
CG00047	121	1222	48.110	11	7
CG00048	123	1242	48.898	11	7
CG00049	125	1262	49.685	12	8
CG00050	127	1282	50.472	12	8
CG00051	129	1302	51.260	12	8
CG00052	131	1322	52.047	12	8
CG00053	133	1342	52.835	12	8
CG00054	135	1362	53.622	12	8
CG00055	137	1382	54.409	13	8
CG00056	139	1402	55.197	13	8
CG00057	141	1422	55.984	13	8
CG00058	143	1442	56.772	13	9
CG00059	145	1462	57.559	13	9
CG00060	147	1482	58.346	13	9
CG00061	149	1502	59.134	14	9
CG00062	151	1522	59.921	14	9
CG00063	153	1542	60.709	14	9
CG00064	155	1562	61.496	14	9
CG00065	157	1582	62.283	14	9
CG00066	159	1602	63.071	14	9
CG00067	161	1622	63.858	15	9
CG00068	163	1642	64.646	15	10
CG00069	165	1662	65.433	15	10
CG00070	167	1682	66.220	15	10
CG00071	169	1702	67.008	15	10
CG00072	171	1722	67.795	15	10
CG00073	173	1742	68.583	16	10
CG00074	175	1762	69.370	16	10
CG00075	177	1782	70.157	16	10
CG00076	179	1802	70.945	16	10
CG00077	181	1822	71.732	16	11
CG00078	183	1842	72.520	16	11
CG00079	185	1862	73.307	17	11
CG00080	187	1882	74.094	17	11
CG00081	189	1902	74.882	17	11
CG00082	191	1922	75.669	17	11
CG00083	193	1942	76.457	17	11
CG00084	195	1962	77.244	17	11
CG00085	197	1982	78.031	18	11
CG00086	199	2002	78.819	18	11
CG00087	201	2022	79.606	18	12

COMPACT-GRID® 10mm (CG10)

BELT WIDTH AVAILABILITY

Belt No.	No. of Spaces	Overall Belt Width		Standard # of Slim Profile Sprockets	Standard # of Stacking Drive Sets
		mm	inches		
CG00088	203	2042	80.394	18	12
CG00089	205	2062	81.181	18	12
CG00090	207	2082	81.969	18	12
CG00091	209	2102	82.756	19	12
CG00092	211	2122	83.543	19	12
CG00093	213	2142	84.331	19	12
CG00094	215	2162	85.118	19	12
CG00095	217	2182	85.906	19	12
CG00096	219	2202	86.693	19	13
CG00097	221	2222	87.480	20	13
CG00098	223	2242	88.268	20	13
CG00099	225	2262	89.055	20	13
CG00100	227	2282	89.843	20	13
CG00101	229	2302	90.630	20	13
CG00102	231	2322	91.417	20	13
CG00103	233	2342	92.205	21	13
CG00104	235	2362	92.992	21	13
CG00105	237	2382	93.780	21	13
CG00106	239	2402	94.567	21	14
CG00107	241	2422	95.354	21	14
CG00108	243	2442	96.142	21	14
CG00109	245	2462	96.929	22	14
CG00110	247	2482	97.717	22	14
CG00111	249	2502	98.504	22	14
CG00112	251	2522	99.291	22	14
CG00113	253	2542	100.079	22	14
CG00114	255	2562	100.866	22	14
CG00115	257	2582	101.654	23	15
CG00116	259	2602	102.441	23	15
CG00117	261	2622	103.228	23	15
CG00118	263	2642	104.016	23	15
CG00119	265	2662	104.803	23	15
CG00120	267	2682	105.591	23	15
CG00121	269	2702	106.378	24	15
CG00122	271	2722	107.165	24	15
CG00123	273	2742	107.953	24	15
CG00124	275	2762	108.740	24	15
CG00125	277	2782	109.528	24	16
CG00126	279	2802	110.315	24	16
CG00127	281	2822	111.102	25	16
CG00128	283	2842	111.890	25	16
CG00129	285	2862	112.677	25	16
CG00130	287	2882	113.465	25	16
CG00131	289	2902	114.252	25	16
CG00132	291	2922	115.039	25	16
CG00133	293	2942	115.827	26	16
CG00134	295	2962	116.614	26	17
CG00135	297	2982	117.402	26	17
CG00136	299	3002	118.189	26	17

Belt No.	No. of Spaces	Overall Belt Width		Standard # of Slim Profile Sprockets	Standard # of Stacking Drive Sets
		mm	inches		
CG00137	301	3022	118.976	26	17
CG00138	303	3042	119.764	26	17
CG00139	305	3062	120.551	27	17
CG00140	307	3082	121.339	27	17
CG00141	309	3102	122.126	27	17
CG00142	311	3122	122.913	27	17
CG00143	313	3142	123.701	27	17
CG00144	315	3162	124.488	27	18
CG00145	317	3182	125.276	28	18
CG00146	319	3202	126.063	28	18
CG00147	321	3222	126.850	28	18
CG00148	323	3242	127.638	28	18
CG00149	325	3262	128.425	28	18
CG00150	327	3282	129.213	28	18
CG00151	329	3302	130.000	29	18
CG00152	331	3322	130.787	29	18
CG00153	333	3342	131.575	29	19
CG00154	335	3362	132.362	29	19
CG00155	337	3382	133.150	29	19
CG00156	339	3402	133.937	29	19
CG00157	341	3422	134.724	30	19
CG00158	343	3442	135.512	30	19
CG00159	345	3462	136.299	30	19
CG00160	347	3482	137.087	30	19
CG00161	349	3502	137.874	30	19
CG00162	351	3522	138.661	30	19
CG00163	353	3542	139.449	31	20
CG00164	355	3562	140.236	31	20
CG00165	357	3582	141.024	31	20
CG00166	359	3602	141.811	31	20
CG00167	361	3622	142.598	31	20
CG00168	363	3642	143.386	31	20
CG00169	365	3662	144.173	32	20
CG00170	367	3682	144.960	32	20
CG00177	13	142	5.591	2	2
CG00178	15	162	6.378	2	2
CG00179	17	182	7.165	3	2
CG00180	19	202	7.953	3	2
CG00181	21	222	8.740	3	2
CG00182	23	242	9.528	3	2
CG00183	25	262	10.315	3	2

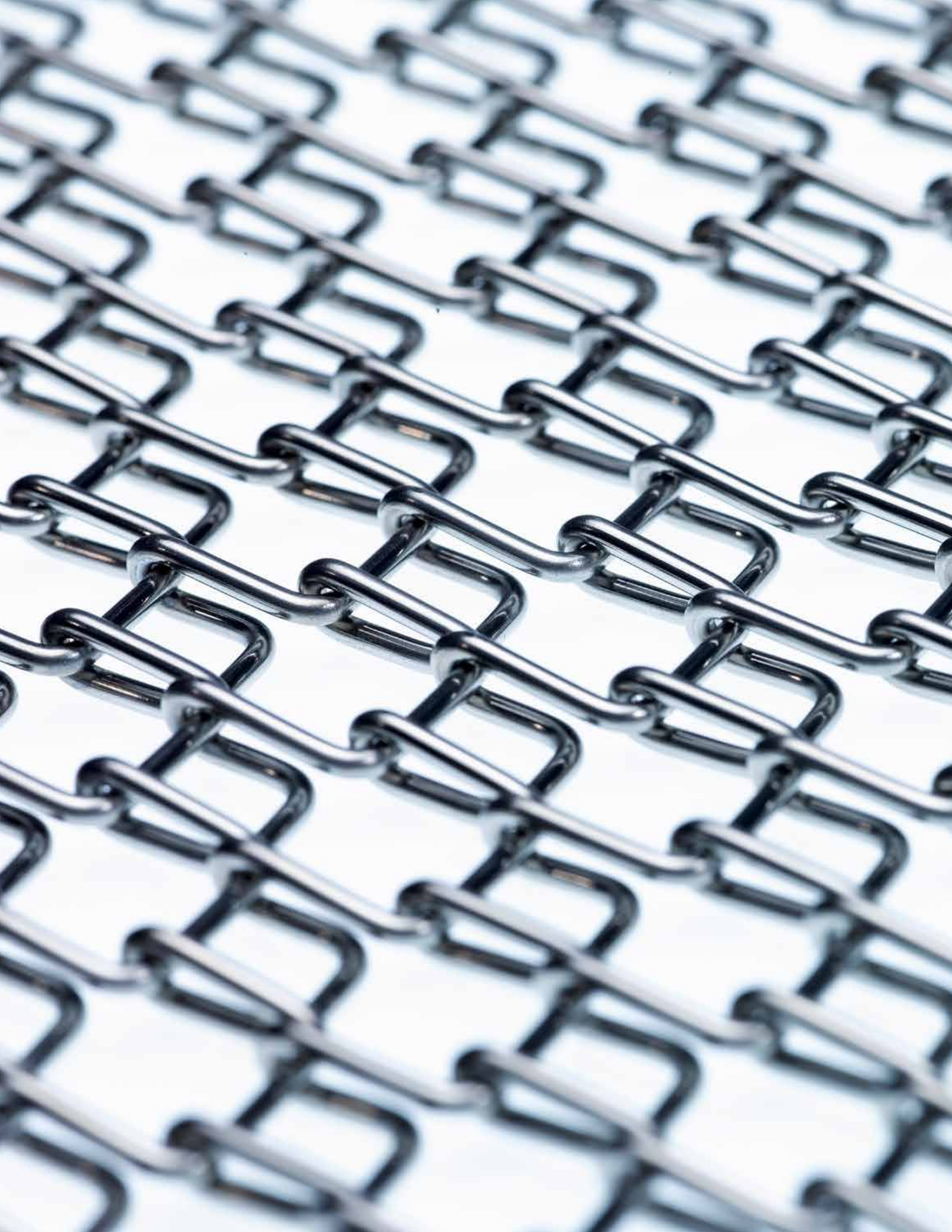

COMPACT-GRID[®] 15mm (CG15)

STANDARD BELT DATA

Pitch	.590"	15mm
Space Width (average)	.590"	15mm
Wire Diameter	.082"	2.08mm
Belt Thickness	.26"	6.7mm
Weight	1.18lbs/ft ²	5.8 kg/m ²
Percent Open Area	73%	73%
Opening Size (largest opening)	ø.63" circle	ø16mm circle
Max Width	120.5"	3061mm
Min Width	10.7"	271mm
Max Working Tension	7.5lb/joint (150lb/ft)	3.41 kg/joint • 227 kg/mtr width
Min Transfer Diameter	1.0"	25mm
Min Drive Sprocket Diameter	3.3"	83.8mm (8 teeth)
Available Materials	1.4310 (302) Stainless Steel 1.4436 (316) Stainless Steel	

Ø16.0 [Ø0.631]
LARGEST CIRCULAR OPENING

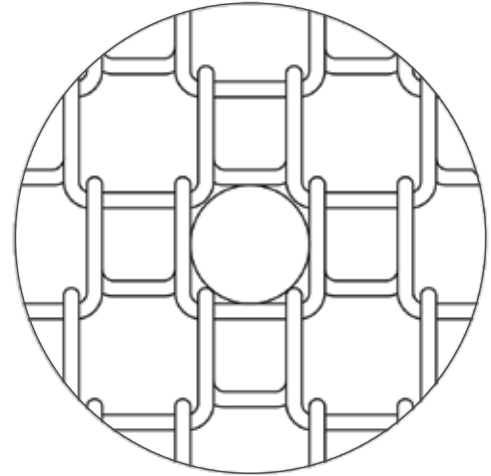

6.7 [0.26]
Belt Thickness

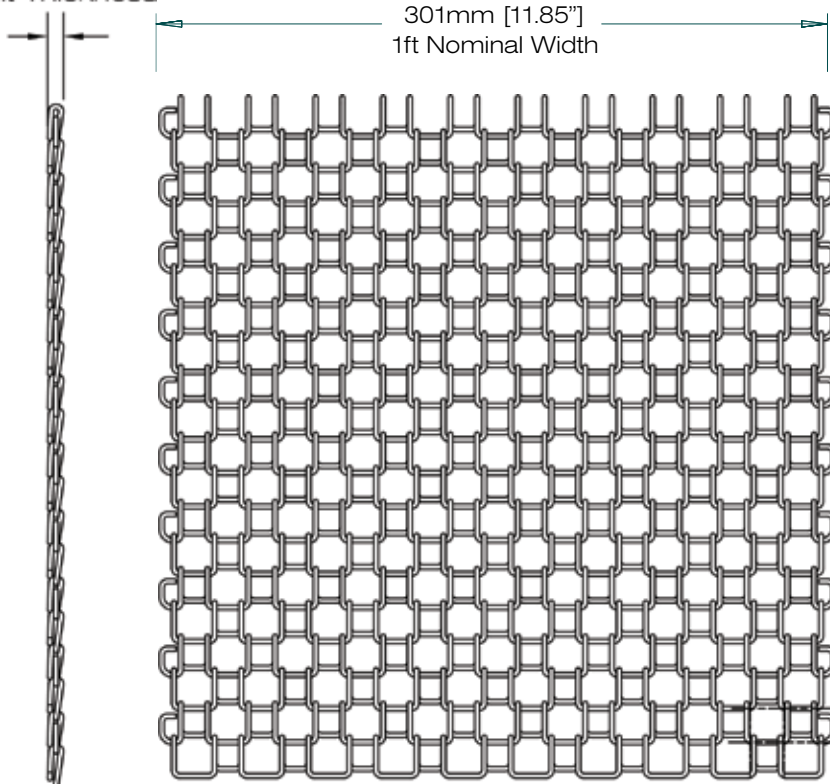

8.0 [0.315]
END SIZE

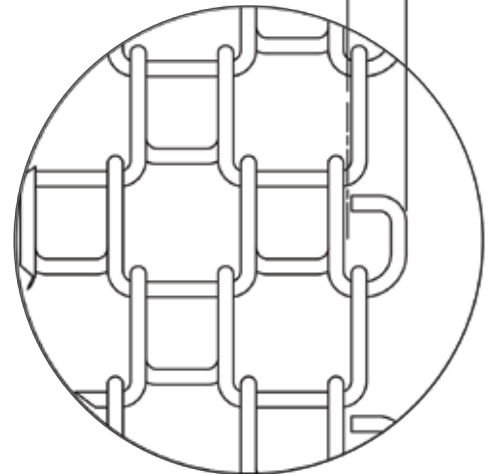

SCALE 1 : 1

15.0 [0.59]
Nominal Space Width

15.0 [0.59]
Pitch



CAUTION:

This belt should not be used on conveyorized sorting or pack-out tables. The mesh openings may be large enough to cause finger trauma. Hands should be kept clear.

COMPACT-GRID® 15mm (CG15)

BELT WIDTH AVAILABILITY

Belt No.	No. of Spaces	Overall Belt Width		Standard # of Slim Profile Sprockets	Standard # of Stacking Drive Sets
		mm	inches		
CG00208	17	271	10.669	2	2
CG00209	19	301	11.850	3	2
CG00210	21	331	13.031	3	2
CG00211	23	361	14.213	3	2
CG00212	25	391	15.394	3	2
CG00213	27	421	16.575	3	2
CG00214	29	451	17.756	3	2
CG00215	31	481	18.937	3	3
CG00216	33	511	20.118	4	3
CG00217	35	541	21.299	4	3
CG00218	37	571	22.480	4	3
CG00219	39	601	23.661	4	3
CG00220	41	631	24.843	4	3
CG00221	43	661	26.024	4	3
CG00222	45	691	27.205	4	3
CG00223	47	721	28.386	5	3
CG00224	49	751	29.567	5	3
CG00225	51	781	30.748	5	3
CG00226	53	811	31.929	5	4
CG00227	55	841	33.110	5	4
CG00228	57	871	34.291	5	4
CG00229	59	901	35.472	5	4
CG00230	61	931	36.654	6	4
CG00231	63	961	37.835	6	4
CG00232	65	991	39.016	6	4
CG00233	67	1021	40.197	6	4
CG00234	69	1051	41.378	6	4
CG00235	71	1081	42.559	6	4
CG00236	73	1111	43.740	6	5
CG00237	75	1141	44.921	7	5
CG00238	77	1171	46.102	7	5
CG00239	79	1201	47.283	7	5
CG00240	81	1231	48.464	7	5
CG00241	83	1261	49.646	7	5
CG00242	85	1291	50.827	7	5
CG00243	87	1321	52.008	7	5
CG00244	89	1351	53.189	8	5
CG00245	91	1381	54.370	8	5
CG00246	93	1411	55.551	8	5
CG00247	95	1441	56.732	8	6
CG00248	97	1471	57.913	8	6
CG00249	99	1501	59.094	8	6
CG00250	101	1531	60.276	8	6
CG00251	103	1561	61.457	9	6
CG00252	105	1591	62.638	9	6
CG00253	107	1621	63.819	9	6
CG00254	109	1651	65.000	9	6
CG00255	111	1681	66.181	9	6

Belt No.	No. of Spaces	Overall Belt Width		Standard # of Slim Profile Sprockets	Standard # of Stacking Drive Sets
		mm	inches		
CG00256	113	1711	67.362	9	6
CG00257	115	1741	68.543	9	7
CG00258	117	1771	69.724	10	7
CG00259	119	1801	70.906	10	7
CG00260	121	1831	72.087	10	7
CG00261	123	1861	73.268	10	7
CG00262	125	1891	74.449	10	7
CG00263	127	1921	75.630	10	7
CG00264	129	1951	76.811	10	7
CG00265	131	1981	77.992	11	7
CG00266	133	2011	79.173	11	7
CG00267	135	2041	80.354	11	7
CG00268	137	2071	81.535	11	8
CG00269	139	2101	82.717	11	8
CG00270	141	2131	83.898	11	8
CG00271	143	2161	85.079	11	8
CG00272	145	2191	86.260	12	8
CG00273	147	2221	87.441	12	8
CG00274	149	2251	88.622	12	8
CG00275	151	2281	89.803	12	8
CG00276	153	2311	90.984	12	8
CG00277	155	2341	92.165	12	8
CG00278	157	2371	93.346	12	9
CG00279	159	2401	94.528	13	9
CG00280	161	2431	95.709	13	9
CG00281	163	2461	96.890	13	9
CG00282	165	2491	98.071	13	9
CG00283	167	2521	99.252	13	9
CG00284	169	2551	100.433	13	9
CG00285	171	2581	101.614	13	9
CG00286	173	2611	102.795	14	9
CG00287	175	2641	103.976	14	9
CG00288	177	2671	105.157	14	9
CG00289	179	2701	106.339	14	10
CG00290	181	2731	107.520	14	10
CG00291	183	2761	108.701	14	10
CG00292	185	2791	109.882	14	10
CG00293	187	2821	111.063	15	10
CG00294	189	2851	112.244	15	10
CG00295	191	2881	113.425	15	10
CG00296	193	2911	114.606	15	10
CG00297	195	2941	115.787	15	10
CG00298	197	2971	116.969	15	10
CG00299	199	3001	118.150	15	11
CG00300	201	3031	119.331	16	11
CG00301	203	3061	120.512	16	11

COMPACT-GRID[®] DRIVE COMPONENTS

THREE STYLES OF SETUPS

Compact-Grid[®] conveyor belt has three differing styles of drive components available: 1-piece sanitary sprockets, 3-piece stacking sprockets, and Slim-Profile sprockets.

The style you use is dependant on factors such as: belt width, belt circuit length, and product loading. Contact our Technical Sales Engineers to see what style would be right for your conveyor setup and application.

1-PIECE SANITARY DRIVE SPROCKETS

Compact-Grid's 1-piece sanitary drive sprockets are made with the highest of hygienic standards in mind. Their one piece design makes them easy to clean, giving debris from your process/application no where to hide.

The 1-piece sanitary design also gives your process the maximum in belt tracking and more consistent conveying under heavier, more demanding loads.



Copyright ©2025 Wire Belt Company Inc.

NOTE: 1-PIECE SANITARY DRIVE SPROCKETS ARE NOT AVAILABLE WITH COMPACT-GRID 15MM (CG15) CONVEYOR BELT.

3-PIECE STACKING SPROCKETS

The 3-piece stacking drive set includes one tracking guide and two drive sprockets. The idler set includes one guide and two blanks. Various numbers of sets will be required across each shaft, and are determined by the belt width, belt length, and product loading. These sprockets are primarily used on heavier loads. If needed, the stackers are an excellent option for running the belt upside down where the tabs of the belt assist the product on a slight incline.



Copyright ©2025 Wire Belt Company Inc.

SLIM PROFILE SPROCKETS

Slim-Profile sprockets are designed to be a light weight and Energy efficient method for driving Compact-Grid conveyor belts. Slim-Profile sprockets have less mass than our 1 or 3-piece options. This means your conveyor won't have to work as hard to keep your process moving.

Slim-Profile sprockets are easy to install and easy to clean on your conveyor. They come in a variety of materials such as stainless steel, polyacetal plastic, or high temperature PEEK material.



Copyright ©2025 Wire Belt Company Inc.

COMPACT-GRID[®] CONVEYOR BELTS

ACCESSORIES

The Compact-Grid[®] joining pliers are manufactured specifically to join the Compact-Grid conveyor belt. The pliers come with two belt joining levers which help facilitate the belt joining process.



Compact-Grid flights are designed to move product up an incline or down a decline. The width and height of the flight is easily customized to accommodate many variations of products. The flight offers multiple fastening sites to assure integrity through the process.

Compact-Grid flights are designed with through-holes and side vents to allow hygienic drainage and drying after cleaning & sanitizing. Proven in field testing to outlast most belts, Compact-Grid flights can easily replace many flighted plastic modular belts.



Distributed by:

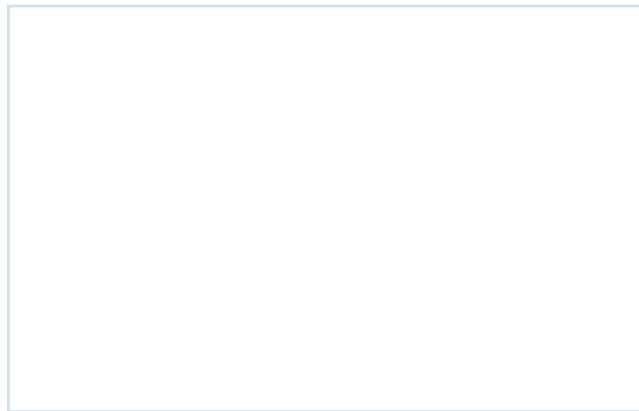

Our policy is one of continuous improvement and we reserve the right to change specifications at any time and without notice, or modify these to suit manufacturing processes.

